

**Modular Cooking Range Line  
 thermaline 85 - 4 Zone Electric Solid Top  
 on Warming Cabinet, 1 Side-Ecotop with  
 Backsplash H=700**

ITEM # \_\_\_\_\_

MODEL # \_\_\_\_\_

NAME # \_\_\_\_\_

SIS # \_\_\_\_\_

AIA # \_\_\_\_\_



**588707 (MBLUGBH4AO)** Electric Solid Top, 4 zones, ecoTop coating, one-side operated, on Warming Cabinet

### Short Form Specification

**Item No.** \_\_\_\_\_

Unit constructed according to DIN 18860\_2 with 20 mm drop nose top. Internal frame for heavy duty sturdiness in stainless steel. 2 mm top in 1.4301 (AISI 304). Flat surface construction, wide rounded, easily cleanable. THERMODUL connection system enables seamless worktop when units are connected and avoids soil penetrating. Solid top made of smooth, pore-free, steel. 4 independently controlled heating zones with 2 electronic sensors per zone for temperature surface control and 8 power levels. Rapid plate heat up, continuously ready to use. Overheat protection switches off the supply in case of overheating. Standby function saves energy and quickly recovers maximum power. Metal knobs with embedded hygienic silicon "soft" grip enable easier handling and cleaning. 800 mm wide warming cabinet with 2 doors, constructed according to DIN 18860\_2 with 70 mm recessed plinth. Internal frame for heavy duty sturdiness in stainless steel. 2 mm top in 1.4301 (AISI 304). Flat surface construction, easily cleanable. THERMODUL connection system enables seamless worktop when units are connected and avoids soil penetrating. Temperature in the cabinet can be set through thermostat, up to a maximum of 110 °C. Cabinet storage space accepts GN 1/1 containers. IPX5 water resistant certification.

### Main Features

- 4 heating zones independently controlled.
- Rapid heat up of the plate and continuously ready for use.
- Overheat protection: the temperature sensor switches off the supply in case of overheating.
- Pans can easily be moved from one area to another without lifting.
- Wide rounded cleaning zone around the plates for easier cleaning.
- All major components may be easily accessed from the front.
- THERMODUL connection system creates a seamless work top when units are connected to each other thus avoiding soil penetrating vital components and facilitating the removal of units in case of replacement or service.
- Metal knobs with embedded hygienic "soft-touch" grip for easier handling and cleaning. The special design of the controls prevents infiltration of liquids or soil into vital components.
- Cooking plate and base joint profile guarantee against soil infiltration.
- Two electronic sensors per zone to control surface temperature and to protect cooking plate from overheating.
- 8 power levels.
- Unit constructed according to DIN 18860\_2 with 70 mm recessed plinth.
- Temperature in the cupboard can be set through a thermostat to suit different requirements. The maximum temperature is 110°C.
- Solid top cooking surface made of 20 mm thick steel, DIN 1.7335, smooth pore-free and easy to clean.

### Construction

- 2 mm top in 1.4301 (AISI 304).
- Flat surface construction with minimal hidden areas to easily clean all surfaces
- Unit constructed according to DIN 18860\_2 with 20 mm drop nose top.
- Storage space in the base of the appliance accepts GN1/1 containers.
- IPX5 water resistance certification.
- Internal frame for heavy duty sturdiness in stainless steel.

### Sustainability

- Standby function for energy saving and fast recovery of maximum power.

### Optional Accessories

- Connecting rail kit for appliances PNC 912498  with backsplash, 850mm
- Stainless steel front kicking strip, PNC 912634  800mm width

**APPROVAL:** \_\_\_\_\_

Front

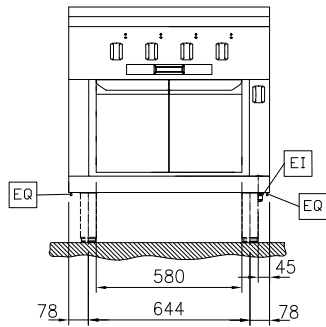

Side

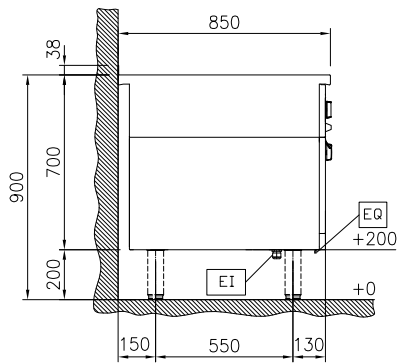

EI = Electrical inlet (power)  
EQ = Equipotential screw

Top

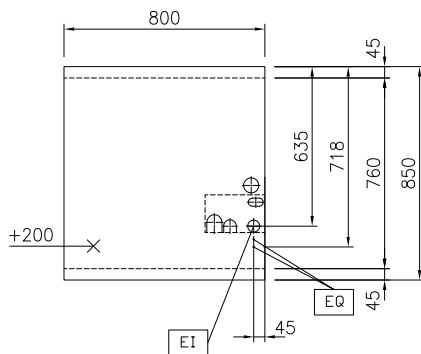

**Electric**

Supply voltage: 400 V/3N ph/50/60 Hz  
Electrical power, max: 14.3 kW

**Key Information:**

Working Temperature MIN: 100 °C  
Working Temperature MAX: 450 °C  
External dimensions, Width: 800 mm  
External dimensions, Depth: 850 mm  
External dimensions, Height: 700 mm  
Net weight: 149 kg  
Configuration: On Oven; One-Side Operated  
Front Plates Power: 3 - 3 kW  
Back Plates Power: 3 - 3 kW  
Solid top usable surface (width): 670 mm  
Solid top usable surface (depth): 650 mm

**Sustainability**

Current consumption: 30.5 Amps